

Hydra-Cell[®]

Seal-less Pumps

Versatile, Reliable Pumps for a Wide Range of Applications



F20 Series

- Pumps the full spectrum of low-to-high viscosity fluids.
- Features a seal-less design and horizontal disk check valves that enable the pump to handle abrasives and particulates that might damage or destroy other types of pumps.
- Simple, compact design reduces initial investment and lowers maintenance costs.
- Operational efficiencies reduce energy costs.
- Able to run dry without damage (or additional maintenance) to the pump in case of accident or operator error.
- Tolerates non-ideal operating conditions.
- Minimizes maintenance and downtime because there are no mechanical or dynamic seals, packing, or cups to leak, wear, or replace.

F20 Series

Maximum Flow Rate: 1.0 gpm (3.8 l/min)

Maximum Pressure: 1500 psi (103 bar) for Metallic Pump Heads
350 psi (24 bar) for Non-metallic Pump Heads



F20 close-coupled for 56C frame motors, shown with Brass pump head.

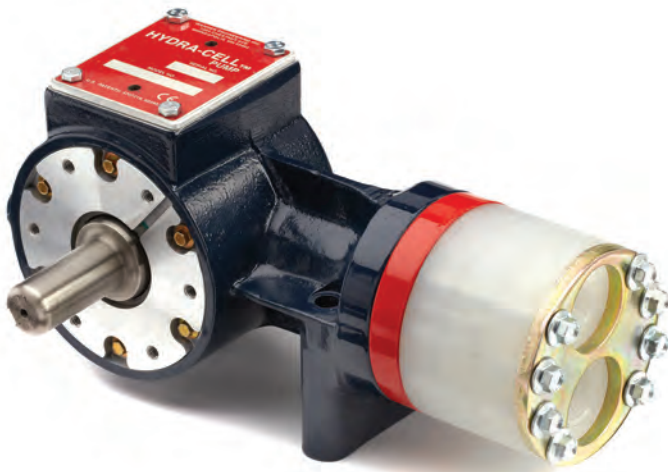

F21 shaft-driven, shown with Polypropylene pump head.



F22 flexible-coupled to 56C, 142TC, and 145TC frame motors, shown with 316L Stainless Steel pump head.

F20 Series Performance

Capacities

Flow

Model	Max. Input rpm	Max. Flow @ 1000 psi (69 bar)	
		gpm	l/min
F20-X	1750	1.01	3.82
F20-E	1750	0.71	2.69
F20-S	1750	0.56	2.12
F20-B	1750	0.31	1.17
F20-G	1750	0.20	0.76

Pressure

Maximum Inlet Pressure
250 psi (17 bar)

Maximum Discharge Pressure

Metallic Pump Heads:

F20 to 1000 psi (69 bar)

F21 to 1500 psi (103 bar)

F22 to 1500 psi (103 bar)

Non-metallic Pump Heads:

250 psi (17 bar) Polypropylene

350 psi (24 bar) PVDF

Performance and specification ratings apply to F20, F21 and F22 configurations unless specifically noted otherwise.

Maximum Flow at Designated Pressure

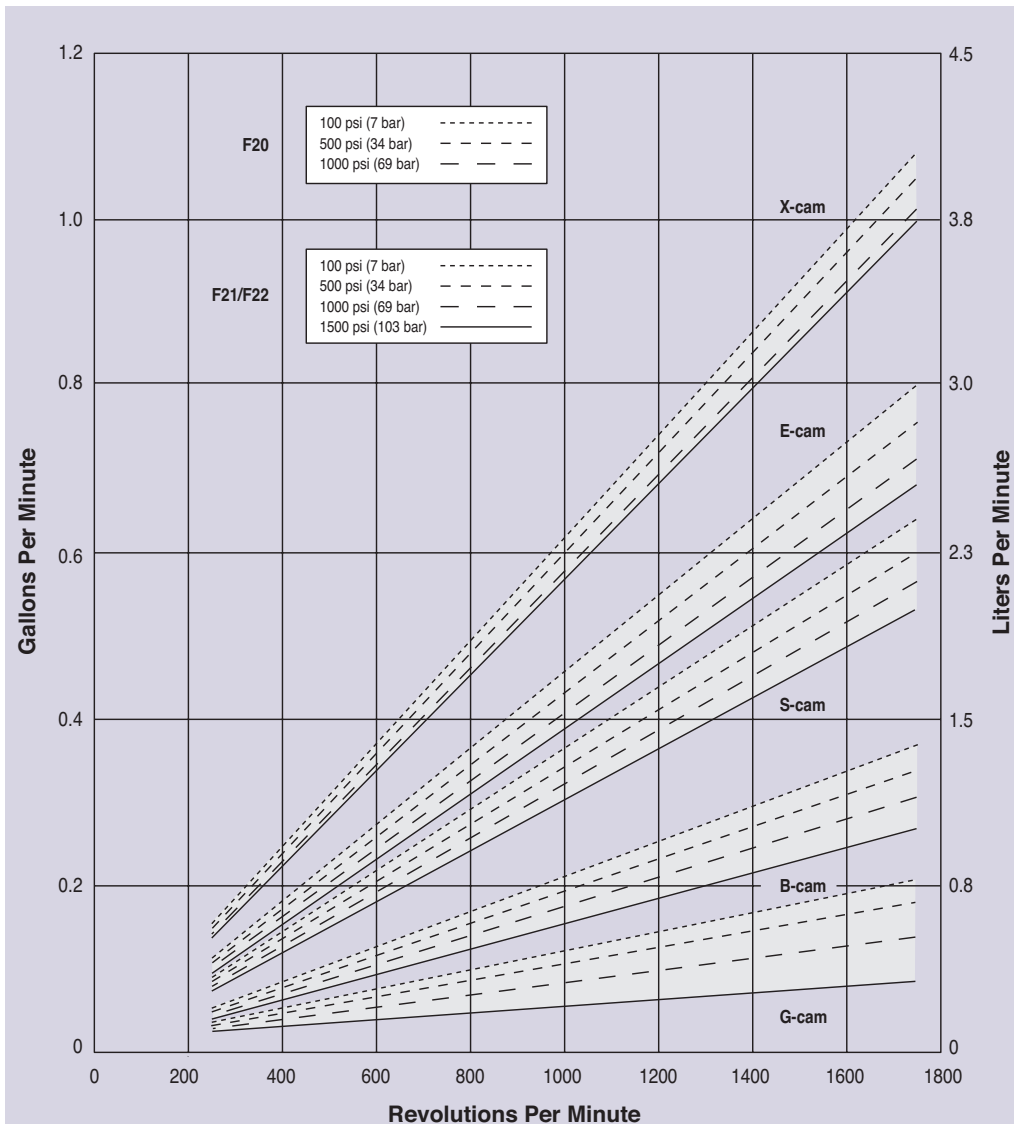

S, B & G cam options based on 10 psi (0.7 bar) inlet pressure.



F20 Series Specifications

Flow Capacities @1000 psi (69 bar)

Model	rpm	gpm	l/min
F20-X	1750	1.01	3.82
F20-E	1750	0.71	2.69
F20-S	1750	0.56	2.12
F20-B	1750	0.31	1.17
F20-G	1750	0.20	0.76

Delivery @1000 psi (69 bar)

Model	gal/rev	liters/rev
F20-X	0.0006	0.0022
F20-E	0.0004	0.0015
F20-S	0.0003	0.0012
F20-B	0.0002	0.0007
F20-G	0.0001	0.0004

Maximum Discharge Pressure

Metallic Heads:	F20 to 1000 psi (69 bar)
	F21 to 1500 psi (103 bar)
	F22 to 1500 psi (103 bar)
Non-metallic Heads:	250 psi (17 bar) Polypropylene
	350 psi (24 bar) PVDF

Maximum Inlet Pressure 250 psi (17 bar)

Maximum Operating Temperature

Metallic Heads:	250 °F (121 °C) - Consult factory for correct component selection for temperatures from 160 °F (71 °C) to 250 °F (121 °C).
Non-metallic Heads:	140 °F (60 °C)

Maximum Solids Size 200 microns

Inlet Port 1/2 inch NPT

Discharge Port 3/8 inch NPT

Shaft Diameter

F20: 5/8 inch hollow shaft
F21 & F22: 5/8 inch (15.9 mm)

Shaft Rotation Reverse (bi-directional)

Bearings Precision ball bearings

Oil Capacity 0.125 US quart (0.12 liters)

Weight

Metallic Heads:	12 lbs. (5.5 kg)
Non-metallic Heads:	9 lbs. (4.1 kg)

Net Positive Suction Head (NPSHr)

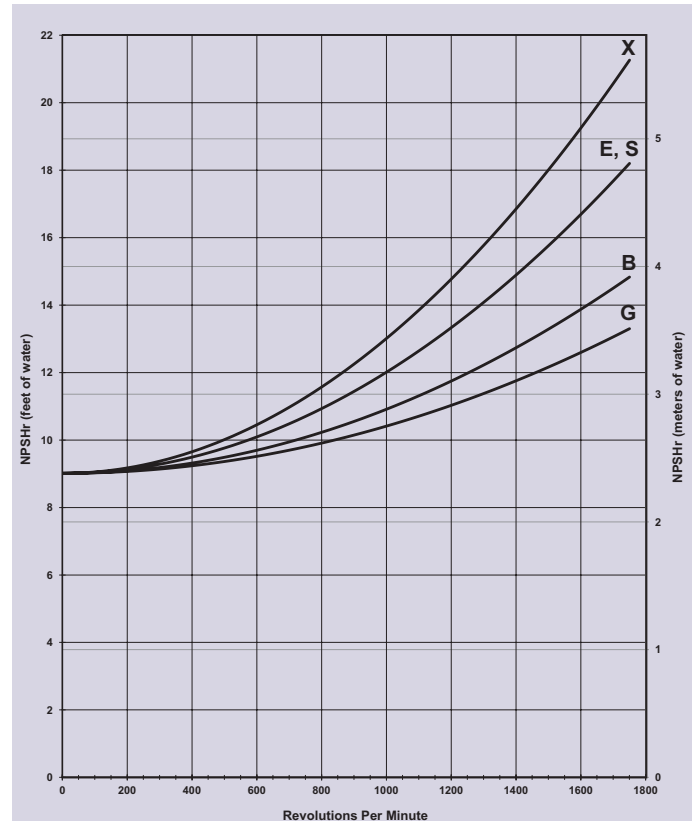

Positive inlet pressure required for:

- A) All pumps with PTFE diaphragms
- B) Pumps with B-cam or G-cam (consult factory)

Self-priming:

Each Hydra-Cell pump has different lift capability depending on model size, cam angle, speed, and fluid characteristics. To ensure that your specific lift characteristics are met, refer to the inlet calculations regarding friction, and acceleration head losses in your Hydra-Cell Installation & Service Manual. Compare those calculations to the NPSHr curves above.

Calculating Required Power

$$\frac{\text{rpm} + 1000}{7000} + \frac{\text{gpm} \times \text{psi}}{1,460} = \text{electric motor hp}$$

$$\frac{\text{rpm} + 1000}{9383} + \frac{\text{l/min} \times \text{bar}}{511} = \text{electric motor kW}$$

When using a variable frequency drive (VFD) controller, calculate the hp or kW at minimum and maximum pump speed to ensure the correct hp or kW motor is selected. Note that motor manufacturers typically de-rate the service factor to 1.0 when operating with a VFD.

F20 Series Representative Drawings

F20 Models with Metallic Pump Head Inches (mm)

*Add 0.25" (6.35mm) where shown for manifold cover plate on non-metallic models.

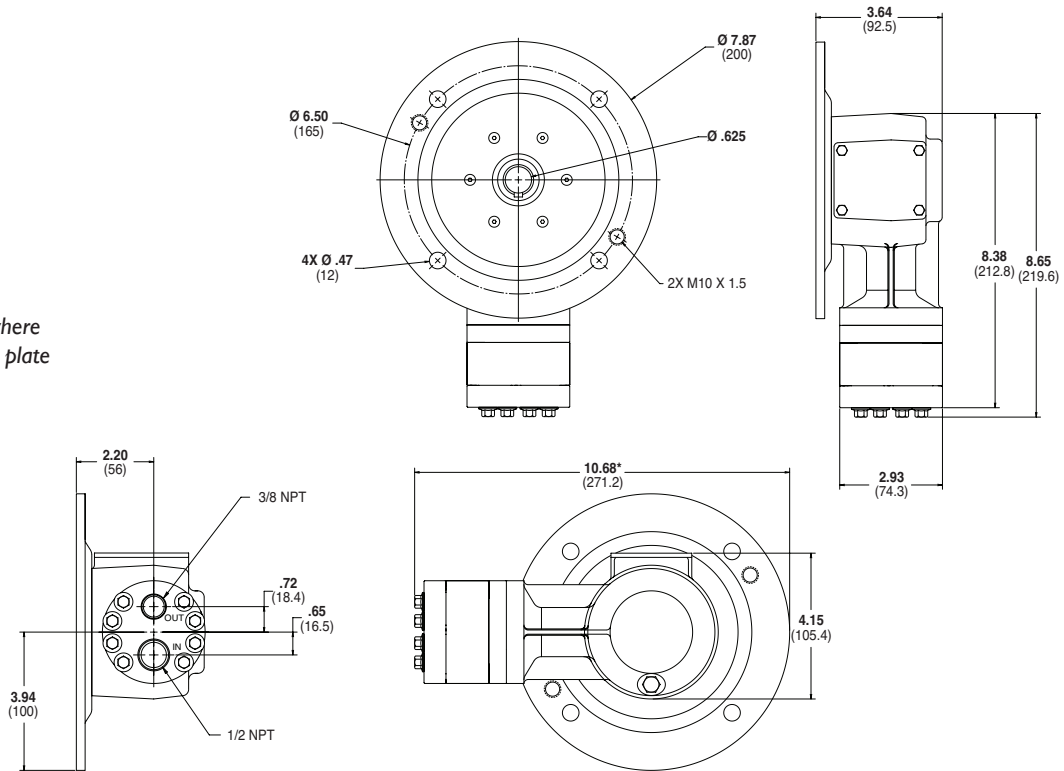

F21 Models with Metallic Pump Head Inches (mm)

*Add 0.25" (6.35mm) where shown for manifold cover plate on non-metallic models.

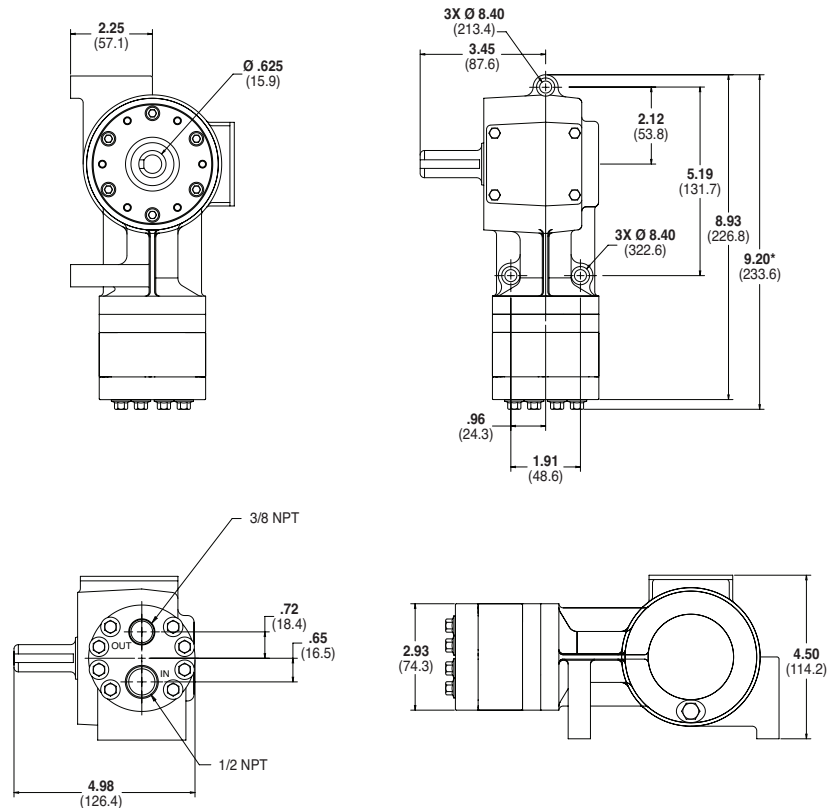

Note: Contact factory for additional drawings of specific models and configurations.

F20 Series Drawings/Adapters/Valves

F22 Models with Metallic Pump Head Inches (mm)

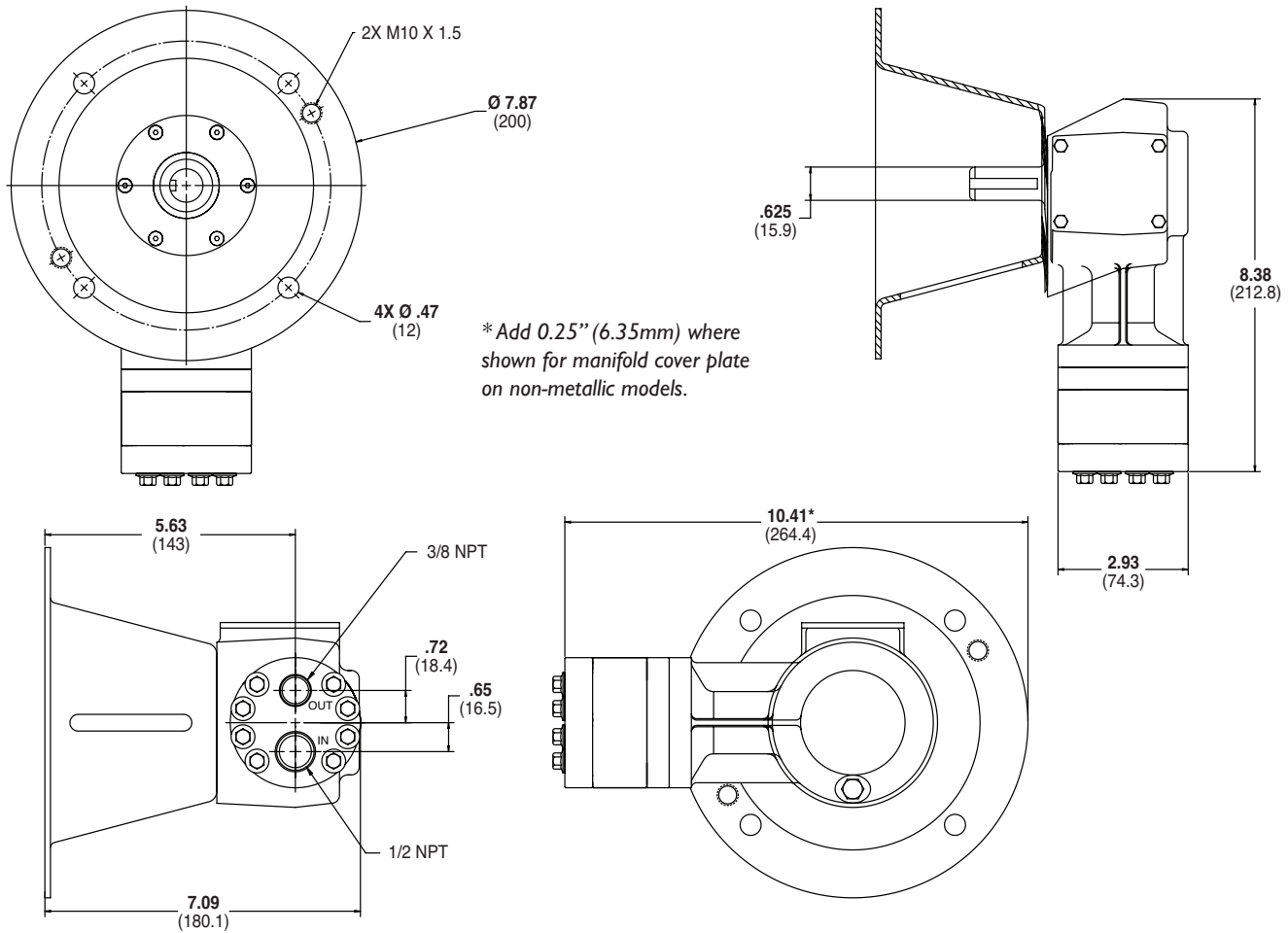

Note: Contact factory for additional drawings of specific models and configurations.

Pump/Motor Adapter Inches (mm)

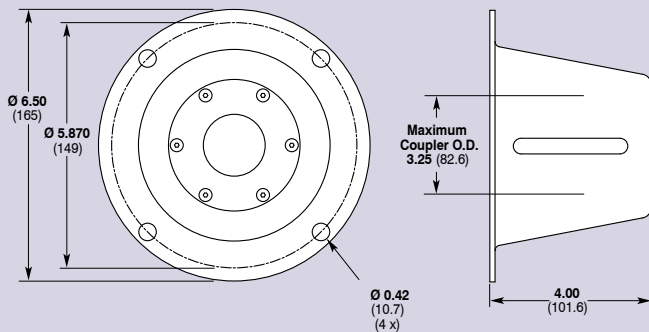

Part Number: A04-005-1200

Must be ordered separately for F22 models for use with 56C, I43TC and I45TC frame motors.

Metric adapter available - consult factory.

Valve Selection

A Hydra-Cell F20, F21 or F22 pumping system uses a C46 Pressure Regulating Valve.



For complete specifications and ordering information, consult the Hydra-Cell Master Catalog.

F20 Series How to Order

Ordering Information

1	2	3	4	5	6	7	8	9	10	11	12
---	---	---	---	---	---	---	---	---	----	----	----

A complete F20 Series Model Number contains 12 digits including 9 customer-specified design and materials options, for example: F20GAPGHFECCG.

Digit	Order Code	Description
1-3	Pump Configuration	
	F20	Close-coupled to NEMA 56C footed motor (NPT Ports)
	F21	Shaft-driven (NPT Ports)*
	F22	For use with pump/motor adapter (NPT Ports)* *Pump/motor adapters ordered separately. See previous page.
4	Hydraulic End Cam	
	X	Max 1.01 gpm (3.8 l/min) @ 1750 rpm
	E	Max 0.71 gpm (2.7 l/min) @ 1750 rpm
	S	Max 0.56 gpm (2.1 l/min) @ 1750 rpm
	B	Max 0.31 gpm (1.2 l/min) @ 1750 rpm**
	G	Max 0.20 gpm (0.8 l/min) @ 1750 rpm**
5	Pump Head Version	
	A	NPT Ports (for all F20, F21 & F22 pumps)
6	Pump Head Material	
	B	Brass
	M	PVDF
	P	Polypropylene
	S	316L Stainless Steel
	T	Hastelloy C
7	Diaphragm & O-ring Material	
	A	Aflas diaphragm/PTFE o-ring
	E	EPDM (requires EPDM-compatible oil - Digit 12 oil code J)
	G	FKM
	J	PTFE (available with X and E cams only)**
	P	Neoprene
	T	Buna-N
8	Valve Seat Material	
	C	Ceramic
	D	Tungsten Carbide
	H	17-4 Stainless Steel
	S	316L Stainless Steel
	T	Hastelloy C

Digit	Order Code	Description
9	Valve Material	
	C	Ceramic
	D	Tungsten Carbide
	F	17-4 Stainless Steel
	N	Nitronic 50
10	Valve Springs	
	E	Elgiloy
	T	Hastelloy C
11	Valve Spring Retainers	
	C	Celcon
	H	17-7 Stainless Steel (used with metallic heads only)
	M	PVDF
	P	Polypropylene
	T	Hastelloy C (used with metallic heads only)
12	Hydra-Oil	
	G	5W30 cold-temp severe-duty synthetic oil
	J	EPDM-compatible oil
	K	Food-contact oil

Consult the Hydra-Cell Master Catalog for:

- Motors, bases, couplings and other pump accessories
- Hydra-Oil selection and specification information
- Design considerations, installation guidelines, and other technical assistance in pump selection

**Positive inlet pressure required for B and G cams and for PTFE diaphragms.

Hydra-Cell[®]

Seal-less Pumps

Wanner Engineering, Inc.

World Headquarters & Manufacturing

Wanner Engineering, Inc.
1204 Chestnut Avenue
Minneapolis, MN 55403 USA
Phone: 612-332-5681 • Fax: 612-332-6937
Toll-Free Fax (USA): 800-332-6812
Email: sales@wannereng.com
www.Hydra-Cell.com

207 US Highway 281
Wichita Falls, TX 76310 USA
Phone: 940-322-7111
Toll-Free: 800-234-1384
Email: sales@wannereng.com
www.Hydra-Cell.com

Latin American Office

R. Álvaro Anes, 150 Bairro Campestre
Santo André/São Paulo, Brazil - CEP 09070-030
Phone: +55 (11) 4081-7098
Email: mmagoni@wannereng.com
www.Hydra-Cell.com

Wanner International Ltd.

Wanner International, Ltd.
Hampshire - United Kingdom
Phone: +44 (0) 1252 816847
Email: sales@wannerint.com
www.Hydra-Cell.eu

Wanner Pumps Ltd.

Wanner Pumps, Ltd.
Kowloon - Hong Kong
Phone: +852 3428 6534
Email: sales@wannerpumps.com
www.WannerPumps.com

Shanghai - China
Phone: +86-21-6876 3700
Email: sales@wannerpumps.com
www.WannerPumps.com

