

# Hydra-Cell®

## Seal-less Pumps

**Versatile, Reliable Pumps for a Wide Range of Applications**

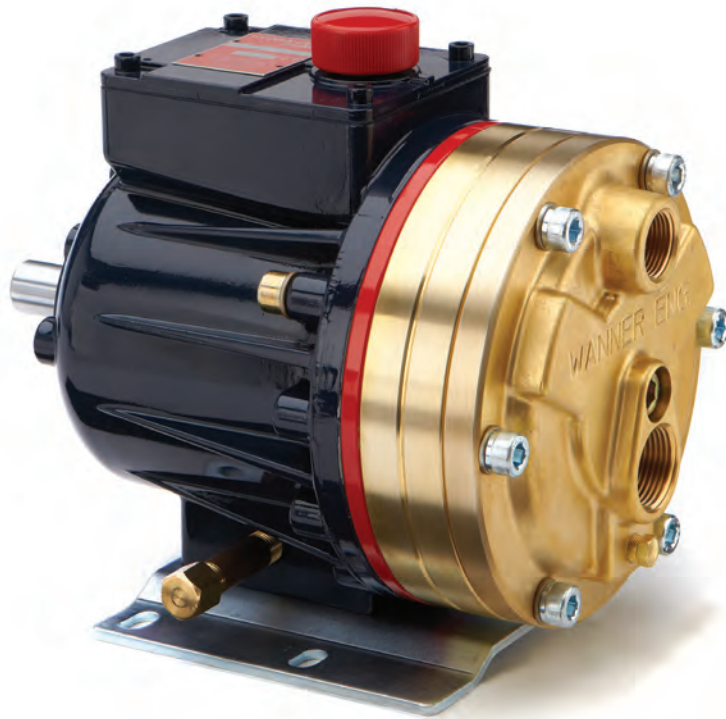

### D10 Series

- Pumps the full spectrum of low-to-high viscosity fluids.
- Features a seal-less design and horizontal disk check valves that enable the pump to handle abrasives and particulates that might damage or destroy other types of pumps.
- Simple, compact design reduces initial investment and lowers maintenance costs.
- Operational efficiencies reduce energy costs.
- Able to run dry without damage (or additional maintenance) to the pump in case of accident or operator error.
- Tolerates non-ideal operating conditions.
- Minimizes maintenance and downtime because there are no mechanical or dynamic seals, packing, or cups to leak, wear, or replace.

# D10 Series

Maximum Flow Rate: 8.8 gpm (33.4 l/min)

Maximum Pressure: 1500 psi (103 bar) for Metallic Pump Heads  
350 psi (24 bar) for Non-metallic Pump Heads

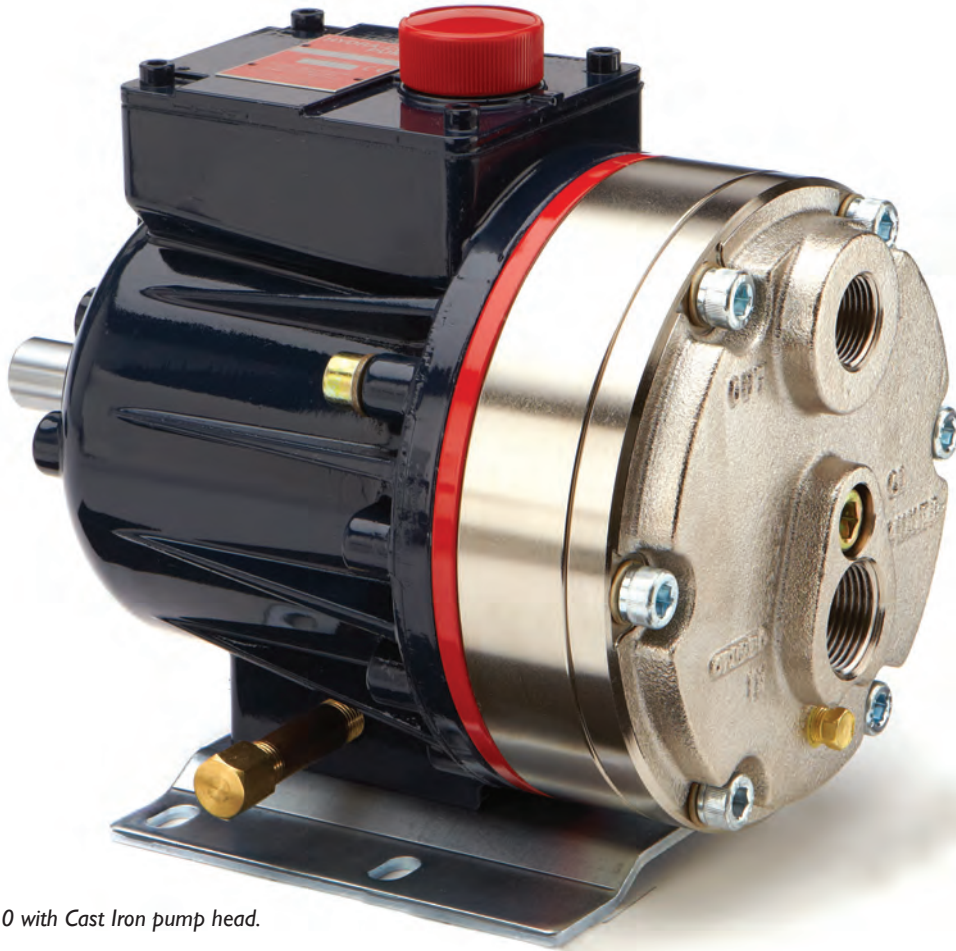

*D10 with Cast Iron pump head.*



*D10 with Brass pump head.*



*D10 with Polypropylene pump head.*



*D10 with 316L Stainless Steel pump head and ANSI flanges.*

# D10 Series Performance

## Capacities

### Flow

Model	Max. Input rpm	Max. Flow	
		@ 1000 psi (69 bar) gpm	l/min
D10-X	1450	8.1	30.6
D10-E	1750	8.8	33.4
D10-S	1750	6.0	22.7
D10-I	1750	4.0	15.0
<b>@ 1500 psi (103 bar)</b>			
D10-X	790	4.26	15.1
D10-E	790	3.87	14.7

### Pressure

#### Maximum Inlet Pressure

250 psi (17 bar)

#### Maximum Discharge Pressure

Metallic Pump Heads:

D10-X, E, S, I to 1000 psi (69 bar)

D10-X to 1500 psi (103 bar) @ 790 rpm max.

Non-metallic Pump Heads:

250 psi (17 bar) Polypropylene

350 psi (24 bar) PVDF

Performance and specification ratings apply to D10 configurations unless specifically noted otherwise.

## Maximum Flow at Designated Pressure

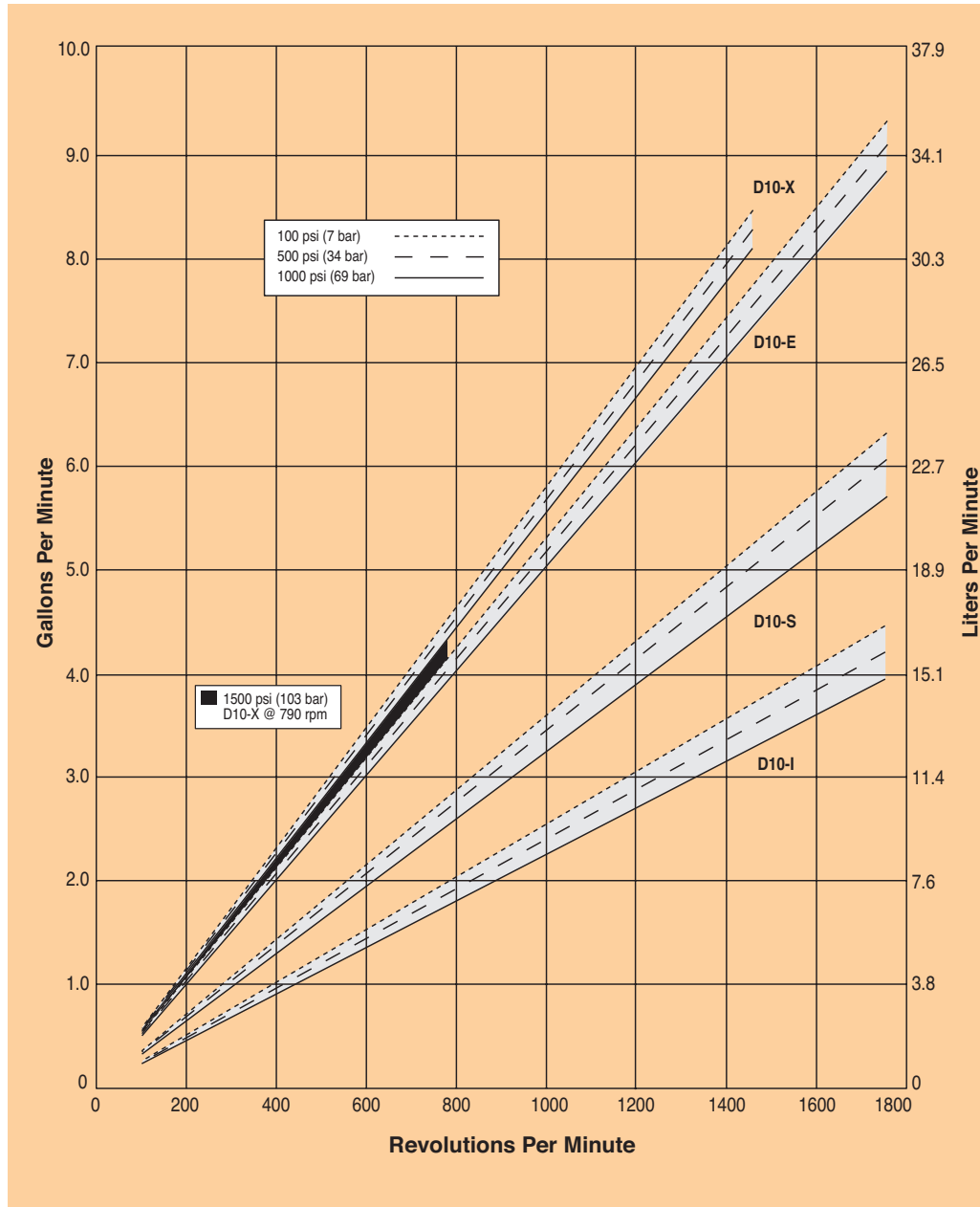

# D10 Series Specifications

## Flow Capacities @1000 psi (69 bar)

Model	rpm	gpm	l/min
D10-X	1450	8.10	30.6
D10-E	1750	8.83	33.4
D10-S	1750	6.00	22.7
D10-I	1750	3.96	15.0

## Delivery @1500 psi (103 bar)

Model	gal/rev	liters/rev
D10-X	0.0054	0.0205
D10-E	0.0049	0.0186

## Delivery @1000 psi (69 bar)

Model	gal/rev	liters/rev
D10-X	0.0056	0.0211
D10-E	0.0051	0.0191
D10-S	0.0034	0.0130
D10-I	0.0023	0.0086

## Maximum Discharge Pressure

Metallic Heads:	1000 psi (69 bar) @1450 rpm (D10-X)
	1000 psi (69 bar) @1750 rpm (D10-E, S, I)
	1500 psi (103 bar) @790 rpm (D10-X)
Non-metallic Heads:	250 psi (17 bar) Polypropylene
	350 psi (24 bar) PVDF

## Maximum Inlet Pressure 250 psi (17 bar)

## Maximum Operating Temperature

Metallic Heads:	250 °F (121 °C) - Consult factory for correct component selection for temperatures from 160 °F (71 °C) to 250 °F (121 °C).
Non-metallic Heads:	140 °F (60 °C)

## Maximum Solids Size 500 microns

## Inlet Port 1 inch NPT 150lb ANSI RF flange

## Discharge Port 3/4 inch NPT 600lb ANSI RF flange

## Shaft Diameter 7/8 inch (22.2 mm)

## Shaft Rotation Reverse (bi-directional)

## Bearings Tapered roller bearings

## Oil Capacity 1.1 US quarts (1.05 liters)

## Weight

Metallic Heads:	48 lbs. (21.8 kg)
Non-metallic Heads:	35 lbs. (15.9 kg)

## Calculating Required Power

$$\frac{15 \times \text{rpm}}{63,000} + \frac{\text{gpm} \times \text{psi}}{1,460} = \text{electric motor hp}$$

$$\frac{15 \times \text{rpm}}{84,428} + \frac{\text{l/min} \times \text{bar}}{511} = \text{electric motor kW}$$

When using a variable frequency drive (VFD) controller, calculate the hp or kW at minimum and maximum pump speed to ensure the correct hp or kW motor is selected. Note that motor manufacturers typically de-rate the service factor to 1.0 when operating with a VFD.

## Net Positive Suction Head (NPSHr)

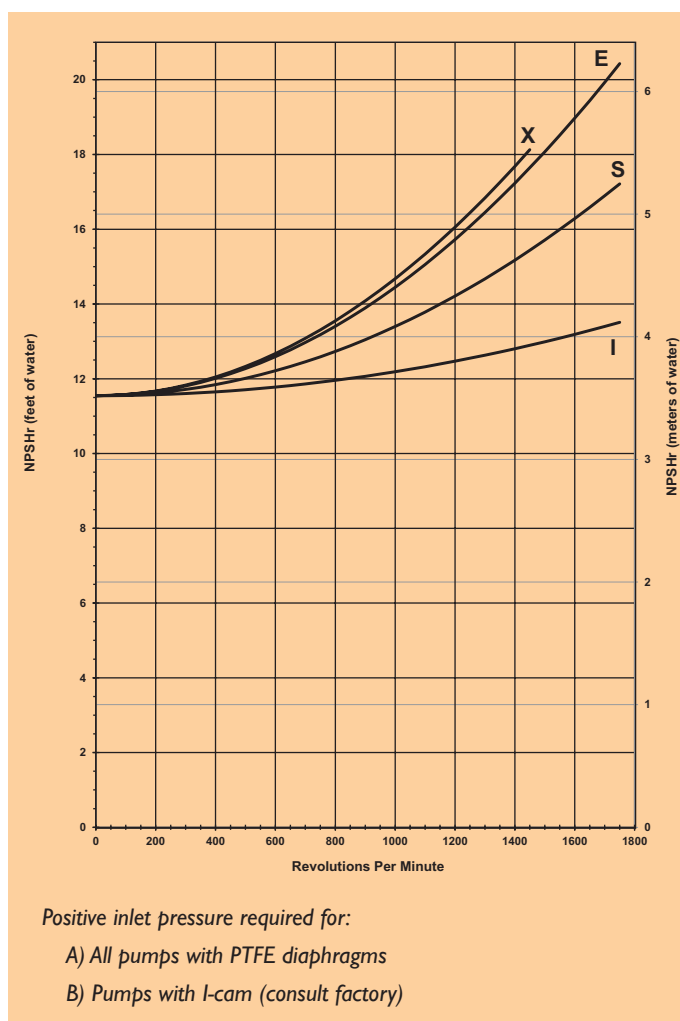

## Self-priming:

Each Hydra-Cell pump has different lift capability depending on model size, cam angle, speed, and fluid characteristics. To ensure that your specific lift characteristics are met, refer to the inlet calculations regarding friction, and acceleration head losses in your Hydra-Cell Installation & Service Manual. Compare those calculations to the NPSHr curves above.

# D10 Series Representative Drawings

## D10 Models with Metallic Pump Head Inches (mm)

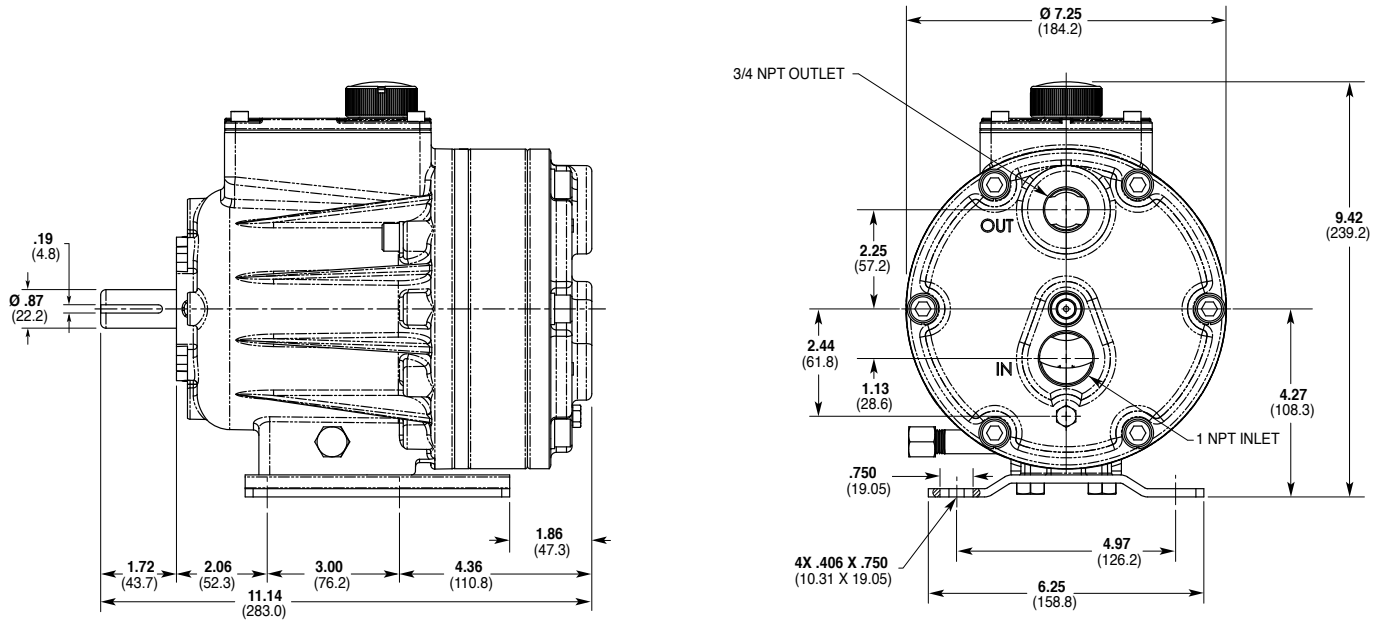

## D10 Models with Non-metallic Pump Head Inches (mm)

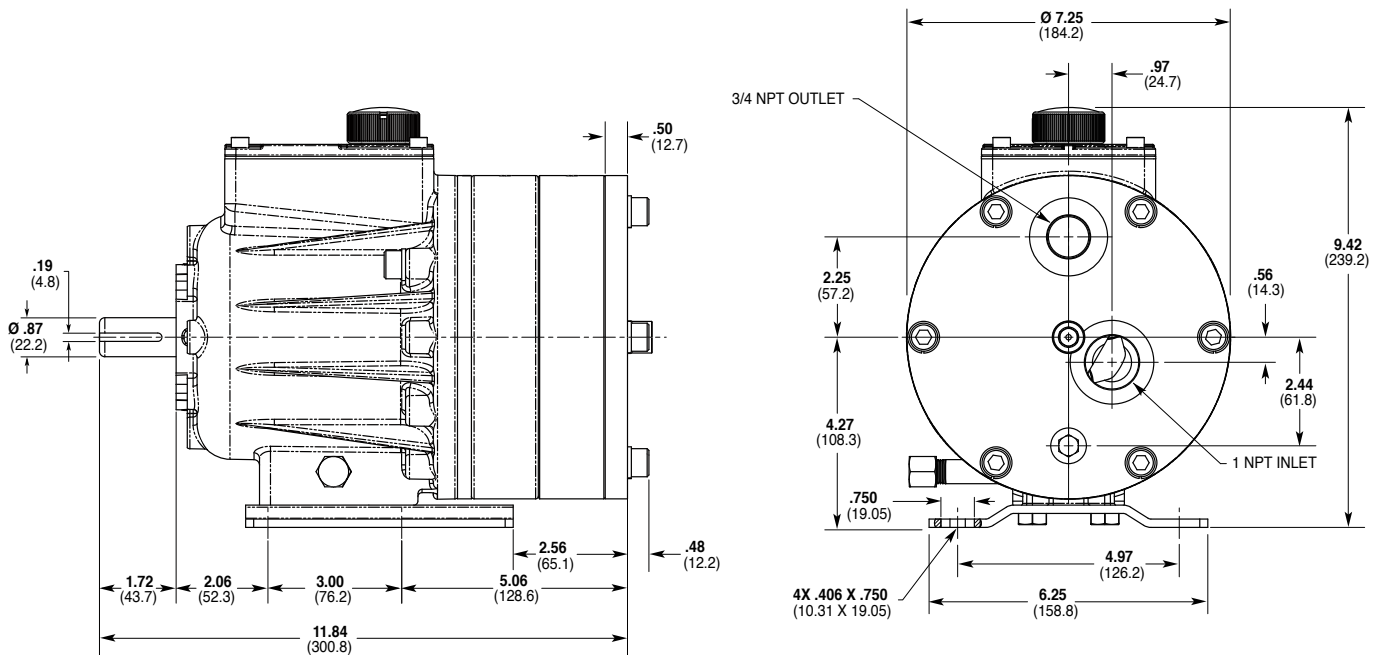

**Note:** Contact factory for additional drawings of specific models and configurations.

# D10 Series **Adapters/Valves**

## Pump/Motor Adapter Inches (mm)

### Part Number: **A04-001-I200**

For: 56C, I43TC and I45TC frame motors.

*Metric adapter available - consult factory.*

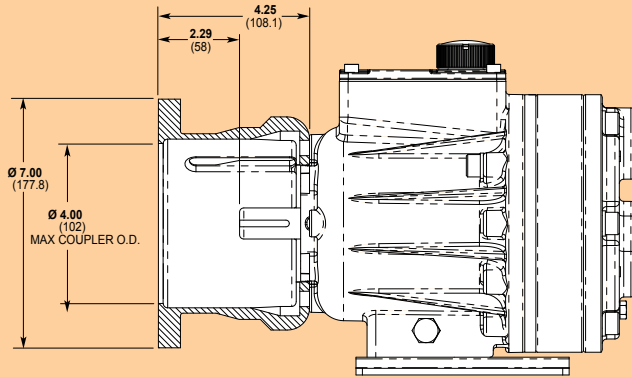

### Part Number: **A04-002-I200**

For: I82TC, I84TC, 2I3TC and 2I5TC frame motors.

*Metric adapter available - consult factory.*

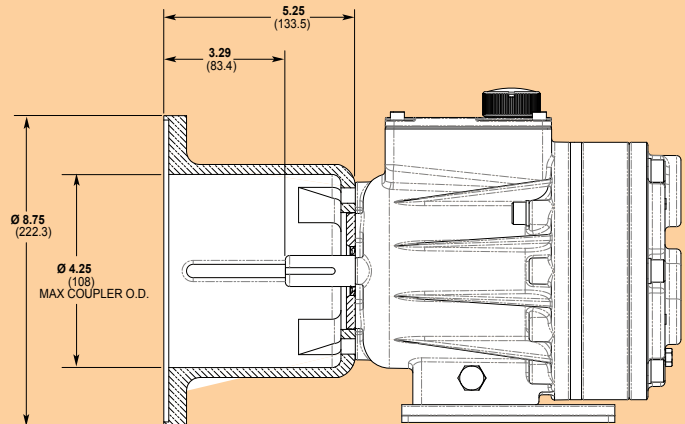

## Valve Selection

A seal-less C62 Pressure Regulating Valve is recommended for Hydra-Cell D10 pumping systems, especially for high-pressure requirements or when handling dirty fluids.



A C22 Pressure Regulating Valve provides a capable, lower-cost alternative to C62 valves for Hydra-Cell D10 pumping systems.



*Skid-mounted D10 with 3hp, 3-phase motor.*

For complete specifications and ordering information, consult the Hydra-Cell Master Catalog.

# D10 Series **How to Order**

## Ordering Information

1	2	3	4	5	6	7	8	9	10	11	12
---	---	---	---	---	---	---	---	---	----	----	----

A complete D10 Series Model Number contains 12 digits including 9 customer-specified design and materials options, for example: D10XKBTHFECA.

Digit	Order Code	Description
<b>1-3</b>	<b>D10</b>	<b>Pump Configuration</b> Shaft-driven (NPT Ports or ANSI Flanges)* *Pump/motor adapters ordered separately. See previous page.
<b>4</b>	<b>X</b>	<b>Hydraulic End Cam</b> Max 8.1 gpm (30.6 l/min) @ 1450 rpm
	<b>E</b>	Max 8.8 gpm (33.4 l/min) @ 1750 rpm
	<b>S</b>	Max 6.0 gpm (22.7 l/min) @ 1750 rpm
	<b>I</b>	Max 4.0 gpm (15.0 l/min) @ 1750 rpm
<b>5</b>	<b>K</b>	<b>Pump Head Version</b> Kel-Cell NPT Ports
	<b>R</b>	Kel-Cell NPT Ports with Optimized Valve Pocket
<b>6</b>	<b>B</b>	<b>Pump Head Material</b> Brass
	<b>C</b>	Cast Iron (Nickel-plated)
	<b>G</b>	Duplex Alloy 2205 (with Hastelloy C followers & follower screws)
	<b>M</b>	PVDF (with Hastelloy C followers & follower screws)
	<b>N</b>	Polypropylene (with Hastelloy C followers & follower screws)
	<b>P</b>	Polypropylene (with 316L Stainless Steel followers & follower screws)
	<b>R</b>	316L Stainless Steel ANSI flange class 150 x 600
	<b>S</b>	316L Stainless Steel
	<b>T</b>	Hastelloy CW12MW
<b>7</b>	<b>A</b>	<b>Diaphragm &amp; O-ring Material</b> Atlas diaphragm / PTFE o-ring
	<b>E</b>	EPDM (requires EPDM-compatible oil - Digit 12 oil code C)
	<b>G</b>	FKM
	<b>J</b>	PTFE (available with E and S cams only; 1200 rpm max.)
	<b>P</b>	Neoprene
	<b>T</b>	Buna-N
<b>8</b>	<b>C</b>	<b>Valve Seat Material</b> Ceramic
	<b>D</b>	Tungsten Carbide
	<b>H</b>	17-4 Stainless Steel
	<b>S</b>	316L Stainless Steel
	<b>T</b>	Hastelloy C

Digit	Order Code	Description
<b>9</b>	<b>C</b>	<b>Valve Material</b> Ceramic
	<b>D</b>	Tungsten Carbide
	<b>F</b>	17-4 Stainless Steel
	<b>N</b>	Nitronic 50
	<b>T</b>	Hastelloy C
<b>10</b>	<b>E</b>	<b>Valve Springs</b> Elgiloy
	<b>H</b>	17-7 Stainless Steel
	<b>T</b>	Hastelloy C
<b>11</b>	<b>C</b>	<b>Valve Spring Retainers</b> Celcon
	<b>H</b>	17-7 Stainless Steel (used with metallic heads only)
	<b>M</b>	PVDF
	<b>P</b>	Polypropylene
	<b>T</b>	Hastelloy C (used with metallic heads only)
	<b>Y</b>	Nylon (Zytel)
<b>12</b>	<b>A</b>	<b>Hydra-Oil</b> 10W30 standard-duty oil
	<b>B</b>	40-wt for continuous-duty oil (use with 316L SST or Hastelloy CW12MW pump head - standard)
	<b>C</b>	EPDM-compatible oil
	<b>E</b>	Food-contact oil
	<b>G</b>	5W30 cold-temp severe-duty synthetic oil
	<b>H</b>	15W50 high-temp severe-duty synthetic oil

D10 Pump Housing is standard as Cast Aluminum. Upgrade to Ductile Iron available.

### Consult the Hydra-Cell Master Catalog for:

- Motors, bases, couplings and other pump accessories
- Hydra-Oil selection and specification information
- Design considerations, installation guidelines, and other technical assistance in pump selection

# Hydra-Cell<sup>®</sup>

## Seal-less Pumps

### **Wanner Engineering, Inc.**

#### **World Headquarters & Manufacturing**

Wanner Engineering, Inc.  
1204 Chestnut Avenue  
Minneapolis, MN 55403 USA  
Phone: 612-332-5681 • Fax: 612-332-6937  
Toll-Free Fax (USA): 800-332-6812  
Email: sales@wannereng.com  
www.Hydra-Cell.com

207 US Highway 281  
Wichita Falls, TX 76310 USA  
Phone: 940-322-7111  
Toll-Free: 800-234-1384  
Email: sales@wannereng.com  
www.Hydra-Cell.com

#### **Latin American Office**

R. Álvaro Anes, 150 Bairro Campestre  
Santo André/São Paulo, Brazil - CEP 09070-030  
Phone: +55 (11) 4081-7098  
Email: mmagoni@wannereng.com  
www.Hydra-Cell.com

### **Wanner International Ltd.**

Wanner International, Ltd.  
Hampshire - United Kingdom  
Phone: +44 (0) 1252 816847  
Email: sales@wannerint.com  
www.Hydra-Cell.eu

### **Wanner Pumps Ltd.**

Wanner Pumps, Ltd.  
Kowloon - Hong Kong  
Phone: +852 3428 6534  
Email: sales@wannerpumps.com  
www.WannerPumps.com

Shanghai - China  
Phone: +86-21-6876 3700  
Email: sales@wannerpumps.com  
www.WannerPumps.com

